

# **FC 1**

**OWNER'S MANUAL**  
**KEEP THIS MANUAL**



The technical specifications and the wiring diagrams contained in this owner's manual are valid only for the model that has the part number indicated below.

FC 1: ALW-FC190500022



# 1. SAFETY PRECAUTIONS - READ BEFORE USING

---



READ SAFETY BLOCKS in welding power source Owner's Manual before proceeding.

## 2. TYPICAL CONNECTION

---

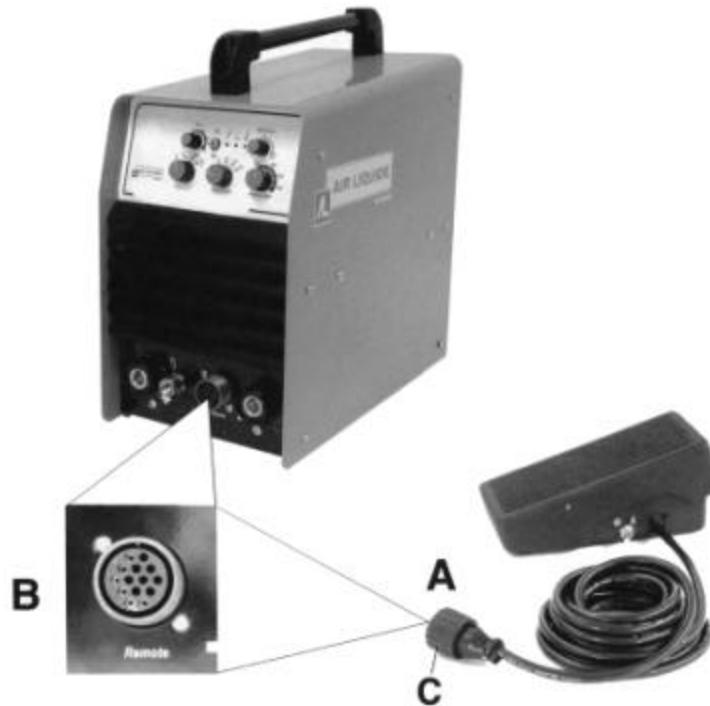

To operate properly, the FC 1 needs to be connected as indicated below.

- 1) Turn welding power source off.
- 2) Insert plug (A) into matching 14 pin receptacle (B) on welding power source.
- 3) Tighten collar (C).
- 4) When the 14 pin plug is connected, the welding power source is automatically set to operate with remote amperage adjustment.

### 3. HOW TO USE THE REMOTE FOOT CONTROL

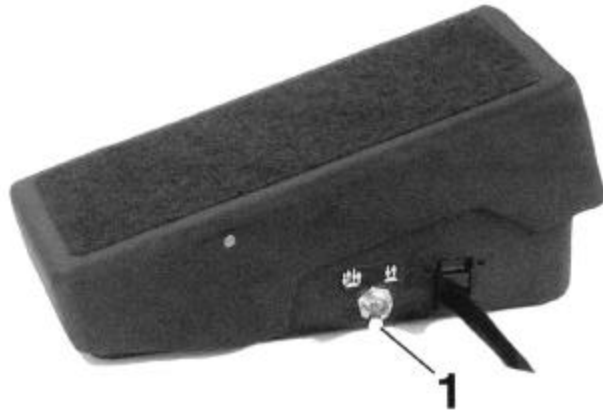

With the selector in the 2T position (See Ref. 1), press the foot control pedal to initiate the welding arc and gas flow.

To increase weld current, depress the foot control pedal. To decrease weld current, release the foot control pedal.

With the selector in the 4T position (See Ref. 1), the foot control pedal operates as a switch only. Weld current is adjusted on the front panel of the welding power source.

### 4. CIRCUIT DIAGRAM

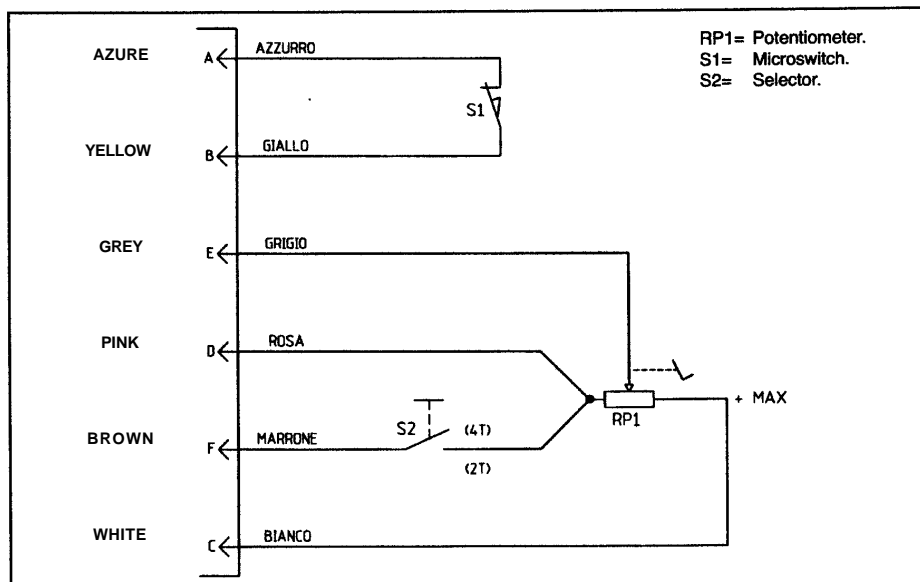

## 5. SPARE PARTS LIST

---

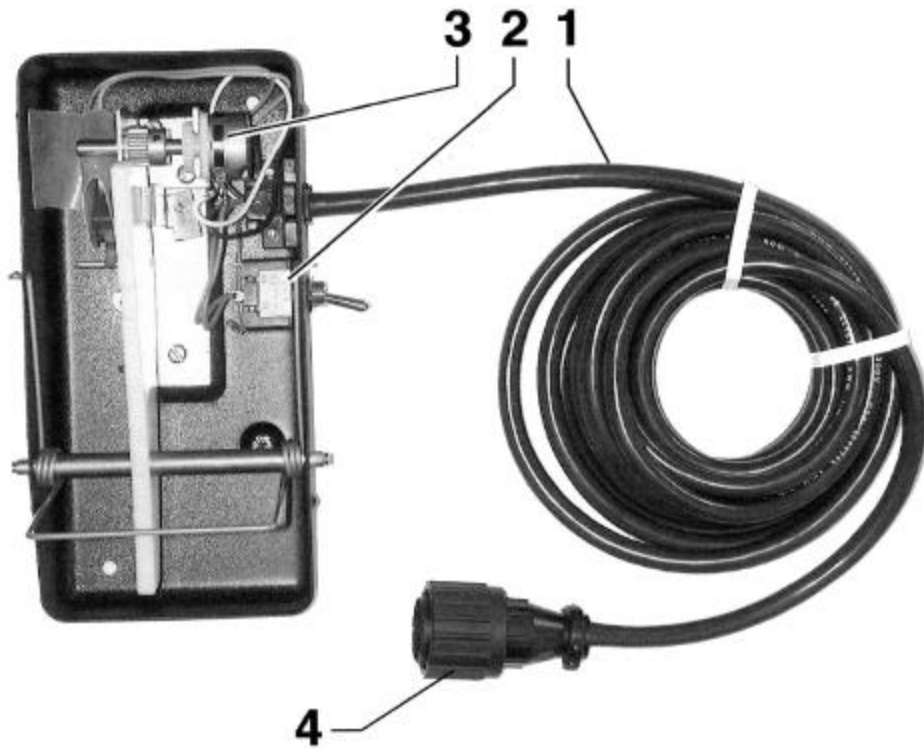

R	PART NUMBER	DESCRIPTION
01	ALW-SP800042289	CABLE
02	ALW-SP035038010	SWITCH
03	ALW-SP041010001	POTENTIOMETER
04	ALW-SP038060001	PLUG